

Alloy Steel Shear Beam Load Cell

FEATURES

- Capacity range: 5,000–10,000 lbs
- Steel and stainless steel construction
- NTEP approved
- IP67 protection
- **Optional**
 - FM approval available

APPLICATIONS

- Low profile platforms
- Pallet truck weighing
- Tank and silo weighing

DESCRIPTION

Model 3420 is a low profile shear beam load cell designed for high accuracy platform scales, pallet scales and process weighing applications.

It has a high immunity to shock or side loading, and is approved to NTEP standards. For hazardous environments this load cell is available with Factory Mutual approval.

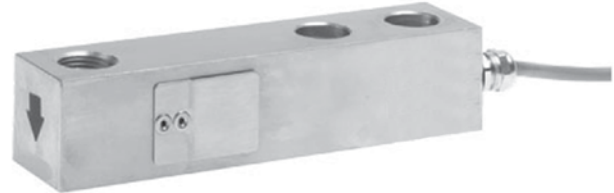

Nickel plating and full environmental sealing assure long-term reliability. A stainless steel option is available for use in harsh or corrosive environments.

The two additional sense wires feed back the voltage reaching the load cell. Complete compensation of changes in lead resistance due to temperature change and/or cable extension can be achieved by feeding this voltage into the appropriate electronics.

OUTLINE DIMENSIONS in millimeters

*Threaded options are available
For full details of all options
contact Tedea-Huntleigh.

3420 plain, M20 or 3/4 - 16 UNF
threaded mounting hole
3421 - 3/4 - 16 UNF

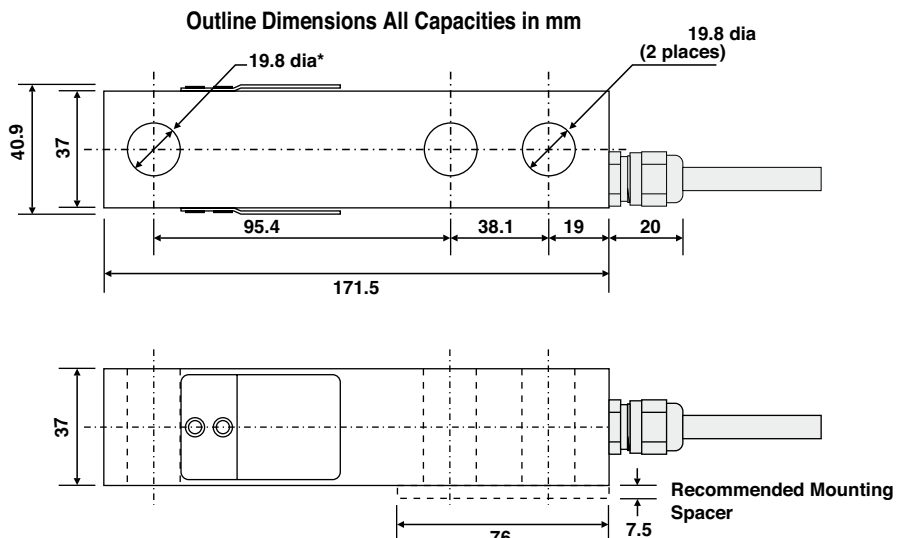

Alloy Steel Shear Beam Load Cell

SPECIFICATIONS			
PARAMETER	VALUE		UNIT
Rated capacity—R.C. (E_{max})	5000, 7500, 10000		lbs
NTEP/OIML accuracy class	NTEP	Non-Approved	
Maximum no. of intervals (n)	3000 single 5000 multiple	3000	
$Y = E_{max}/V_{min}$	6666	10000	
Rated output—R.O.	3.0		mV/V
Rated output tolerance	0.1		±% of rated output
Zero balance	2		±% of rated output
Zero return, 30 min.	0.0250	0.0170	±% of applied load
Total error (per OIML R60)	0.0200	0.0200	±% of rated output
Temperature effect on zero	0.0023	0.0023	±% of rated output/°C
Temperature effect on output	0.0010	0.0010	±% of applied load/°C
Temperature range, compensated	-10 to +40		°C
Temperature range, safe	-20 to +70		°C
Maximum safe central overload	150		% of R.C.
Ultimate central overload	300		% of R.C.
Excitation, recommended	10		VDC or VAC RMS
Excitation, maximum	15		VDC or VAC RMS
Input impedance	385±10		Ω
Output impedance	351±5		Ω
Insulation resistance	>2000		MΩ
Cable length	3.0m—3420 20 ft.—3421		
Cable type	6-wire, braided, polyurethane, floating screen		Standard
Construction	Nickel-plated alloy steel		
Environmental protection	IP67		
Recommended torque	205		N*m

All specifications subject to change without notice.

Wiring Schematic Diagram (Balanced temperature compensation)

